

Polar LOOK Kéo Power

User Manual



POLAR[®]
LISTEN TO YOUR BODY

Contents

1. PRODUCT ELEMENTS.....	3	9. IMPORTANT INFORMATION	17
2. INTRODUCTION	4	Changing Batteries.....	17
3. INSTALL BATTERIES.....	7	Changing Transmitter Sealing Rings.....	17
4. SET CRANK LENGTH.....	9	Maintenance.....	17
5. INSTALL PEDALS	10	Technical Specifications	18
6. INSTALL TRANSMITTERS.....	12	Limited International Polar Guarantee.....	19
7. TEACH TRANSMITTERS TO CYCLING COMPUTER	13	LOOK Limited Warranty	20
8. TRAINING	15	Disclaimer	21

1. PRODUCT ELEMENTS

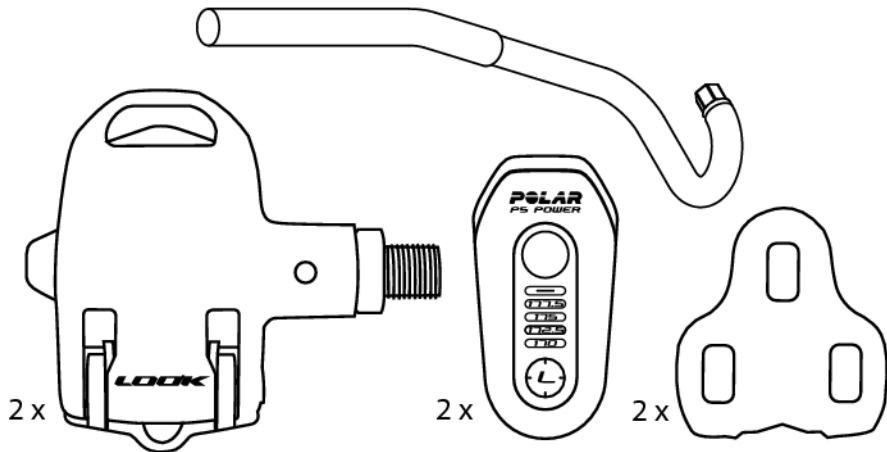

2. INTRODUCTION

Together with a Polar cycling computer (CS600X, CS600 and CS500), Polar LOOK Kéo Power system provides the following training information:

- Actual, average and maximum power values
- Left/Right Balance (CS600X and CS600 only)
- Cycling cadence
- Cycling efficiency (CS600X and CS600 only)

For information on the power features of your cycling computer, refer to the user manual of the cycling computer in question.

The latest versions of the user manuals can be downloaded at www.polar.fi/support and www.lookcycle.com/en/int/infos/support-technique/index.html.

For video tutorials of the Polar LOOK Kéo Power, go to www.polar.fi/en/support/video_tutorials or www.lookcycle.com.

The power output measurement of the Polar LOOK Kéo Power system is based on strain gauges. There are eight strain gauges attached to each pedal axle. Each pedal axle has two measuring circuits, and each circuit has four strain gauges. The force applied to the pedals bends the axle slightly, and causes the strain gauges to lengthen or shorten. This leads to a change in the resistance of the gauges. By measuring the change in resistance, the force applied to each pedal can be determined, and the power output generated while cycling can be measured. Cycling cadence is measured with a magnet located in the pedal.

The power output measurement is performed simultaneously from both pedals with identical measurement systems. This enables accurate comparison of left and right leg power output. The total power output of the cyclist is the sum of the power outputs of both legs. The right transmitter sends the power output and cadence data from the right pedal to the left transmitter. The left transmitter then sends the power output and cadence data from both pedals to the cycling computer.



READ THIS FIRST!

Bicycle riding is an inherently dangerous activity. To reduce the risk of serious injury, be sure your bicycle is adequately maintained and that all components are correctly installed and adjusted. Always wear a helmet and follow the rules of the road when cycling. Do not rely on reflectors. Always use a proper headlight and tail lights when riding at any time of reduced visibility.

Kéo Power pedals are not intended for beginning cyclists, and they are not designed to release automatically in a fall or crash. Proper use by skilled riders will increase riding efficiency and performance, but pedals may be an aggravating factor in the event of a fall or collision. Do not use your Kéo Power pedals with 'street' shoes or with cleats other than LOOK Kéo cleats, as your feet may slip off and cause a crash.



- This Kéo Power pedal is construction and optimized to be used by cyclists less than 100 kgs (220.5 lbs).
- Before going on the road, make sure you are used to the function of your new pedals.
- Practice engaging and disengaging your new pedals while stationary, and train yourself mentally to disengage your pedals at every stop or in other situations where you may need to steady yourself with a foot on the ground.

- The material of the Kéo cleats is especially designed to be compatible with the body of your Kéo. Using other than LOOK Kéo cleats can seriously damage your pedals, and creates a real risk of malfunction.
- Please read these instructions carefully and completely before installing or using these pedals, and keep these instructions in a safe place for future reference. If you have any questions during the installation or adjustment of your Kéo Power pedals, please contact your authorized dealer.
- LOOK reserves the right to change product specifications without prior notice.



LIFESPAN - WEAR - INSPECTION REQUIREMENT

The lifespan of LOOK components depends on many factors, such as rider size and riding conditions. Impacts, falls, improper use or harsh use in general may compromise the structural integrity of the components and significantly reduce their lifespan. Some components are also subject to wear over time. Please have your bicycle regularly inspected by a qualified mechanic for any cracks, deformation, signs of fatigue or wear. If the inspection reveals any deformation, cracks, impact marks or stress marks, no matter how slight, immediately replace the component; components that have experienced excessive wear also need immediate replacement. The frequency of inspection depends on many factors; check with your authorized LOOK representative to select a schedule that is best for you. If you weigh 85 kg/185 lbs or more, you must be especially vigilant and have your bicycle inspected more frequently (than someone weighting less than 85 kg/185 lbs) for any evidence of cracks, deformation, or other signs of fatigue or stress.

3. INSTALL BATTERIES

Before training, install batteries to both transmitters.

1. Open the cover by turning it counterclockwise.
2. Place the battery (CR2354) inside the cover with the positive (+) side facing the cover.
3. Put the cover with the battery inside it in place, and close it by turning clockwise.

Before taking the transmitters into use, they must be paired. The pairing is done automatically when transmitters are switched on for the first time.

1. Make sure there are no other transmitters nearby. This ensures that your transmitters are paired together, and not with any other transmitters.
2. Switch the transmitters on by pressing the left transmitter button for 1 second. A blinking red light indicates the pairing is in process.
3. A blinking green light indicates the pairing is complete.



ENGLISH

Pair Transmitters Manually



The transmitters can also be paired manually.

1. Press and hold the left transmitter button for 10 seconds (green light blinks 10 times).
2. A blinking red light indicates the pairing is in process.
3. A blinking green light indicates the pairing is complete.

4. SET CRANK LENGTH

Before starting training for the first time, set your crank length on the left transmitter. Press and hold the button on the left transmitter for 5 seconds to access the crank length selection mode (green battery light blinks 5 times). Press the button for 1 second to change the crank length. When the correct crank length light is static, wait for 10 seconds to have the crank length stored.

There are four possible crank lengths. These are 170 mm, 172.5 mm, 175 mm and 177.5 mm. The default value is 172.5 mm.

-  *To change the selected crank length at any time, press and hold the left transmitter button for 5 seconds to access the crank length selection mode.*
-  *When switching the transmitters and pedals from one bike to another, make sure the correct crank length is chosen.*

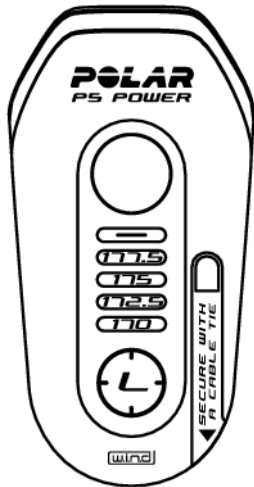

5. INSTALL PEDALS

Carefully read all these instructions before use to get the best out of the product. The specifications may be changed without notice when improvements are made in this product.

To install the pedals, you will need a thin 18 mm wrench, an 8 mm Allen key and the pedal installation tool (provided in product package).

Kéo Power pedals are standard 9/16 x 20 BSA threading. Check that your cranks have the same threading before installing the pedals.

The right pedal screws onto the crank clockwise. The left pedal, marked with a groove on the pedal bolt, screws onto the crank counterclockwise. Make sure the crank thread and face in contact with the pedal axle and bolt are clean before installing the pedals. If they are not clean, the pedal axle may be damaged during installation. Also, check that the ring in front of the pedal bolt is in place.

1. Screw the pedal onto the crank. Make sure to screw it as far as it goes but do not tighten it.
2. Unscrew the pedal so that the mark on the pedal axle points forward when the crank is facing up (picture 1 on page 10). If the pedal axle sticks out of the inside of the crank, put an additional ring (included in package) between the crank and the pedal bolt.
3. Place the pedal installation tool into the pedal axle so that its shaft is in line with the crank (picture 2 on page 10).
4. Hold the pedal installation tool in place, and tighten the pedal bolt with a thin 18 mm wrench. The recommended tightening torque is 30 Nm.



Kéo power pedals are designed to be compatible with cranks less than 16 mm thick. If your cranks are thicker, you may not be able to attach the transmitters to the pedals.

1.

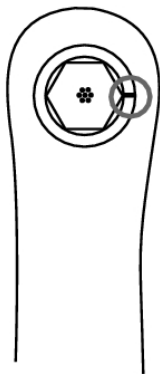

2.

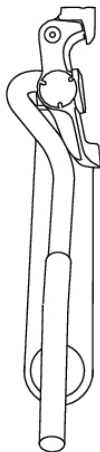

Check the pedal positioning to allow correct transmitter attachment to pedal.



The use of any device joining the cycling shoes to the pedals such as toe clips or clipless pedals may increase or decrease the risk of injury resulting from a fall or a collision. If you are unsure about the installation and adjustment of your Kéo Power pedal, you should have the work completed by a LOOK cycling product dealer.

6. INSTALL TRANSMITTERS

After installing the pedals, install the transmitters to the bike. The transmitters are marked R (right), and L (left). With correct pedal installation, the transmitters point forward when the cranks face up. See picture for correct transmitter positioning.

Perform the steps below to both transmitters:

1. Remove the protective cap from the transmitter.
2. Insert the transmitter into the pedal axle. Check that the shape of the transmitter corresponds with the shape inside the pedal axle. Push firmly but do not use too much strength. Using too much strength can damage the transmitter.
3. Check that the transmitter is positioned correctly (see picture). If the transmitter is in an incorrect position, remove it and adjust the pedals so that the transmitter attaches correctly.

4. Pass the cable tie through the hole in the transmitter. Press and hold the transmitter in place, and tighten the cable tie around the crank. Cut off any excess ends.
5. **Before cycling, rotate the cranks with the chain on the outer chainring and smallest sprocket, and check that the transmitters do not hit any part of the bike or the chain. The system is not compatible with all bike setups.**

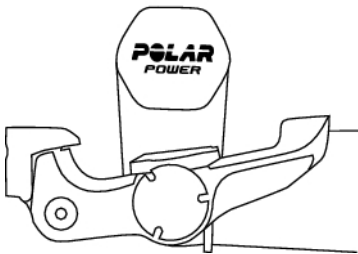

7. TEACH TRANSMITTERS TO CYCLING COMPUTER

The Polar LOOK Kéo Power system is compatible with Polar CS600X, CS600 and CS500 cycling computers. Before training for the first time, the transmitters must be taught to the cycling computer.

To teach the transmitters, switch them on by pressing the button on the left transmitter for 1 second.

CS600 and CS600X

Select **Settings** > **Bike** > **Bike 1/2/3** > **Power** > **On/Off**. **Teach new sensor?** is displayed.

Select **Yes** to confirm teaching. **Start test drive** is displayed.

Completed is displayed when the teaching is complete.

CS500

Select **Settings** > **Bike SET** > **Bike 1 / 2 / 3** > **Power SET** > **ON**.

C. length: Set chain length as 1473 mm. Accept the set value with OK.

C. weight: Set chain weight as 304 g. Accept the set value with OK.

S. length: Set span length as 420 mm. Accept the set value with OK.

Power TEACH? is displayed. To confirm teaching, press OK. **Test drive** is displayed.

Completed is displayed when the teaching is complete.

ENGLISH

Default Power Settings

For the Polar LOOK Kéo Power system to work properly, the cycling computer must use the default power settings. Even if you know the correct settings for your bike, do not use them. Set them as:

Chain weight: 304 g

Chain length: 1473 mm

Span length: 420 mm

8. TRAINING

Calibration

The Polar LOOK Kéo Power system is automatically calibrated each time the transmitters are switched on. During calibration the transmitters are measuring zero power values.

Switch power on by pressing the button on the left transmitter for 1 second. A blinking red light indicates the transmitter is on, and calibration is in process. Do not move the cranks or pedals for 2 seconds. A blinking green light indicates the calibration is complete. After the calibration, the crank length light will blink for 30 seconds showing your crank length.

Important Calibration Information

- Switch the transmitters on outside, to ensure calibration is done in training conditions.
- If the temperature changes 10°C or more during training, calibrate again.
- If you are unsure if the calibration succeeded, switch the transmitters off, and then back on.
- If the calibration fails, a static red light is on for 5 seconds, and the transmitters switch off.



If the calibration is interrupted, the measured power values will be incorrect.

Start Training

Activate your cycling computer. The cycling computer detects the transmitters automatically.

Press START to start the recording.

A blinking green transmitter light indicates training can be started. When pedaling is started, and cadence data is received, the green light will blink for 30 seconds, and then switch off. When pedaling is stopped, the green light will start blinking again.

Stop Training

To pause your training session, press STOP on your cycling computer. To stop recording, press STOP again.

To switch the transmitters off, press the left transmitter button for 1 second.



The transmitters will automatically switch off if the pedals measure 0 power values for 30 minutes.

Transmitter LED Light Color Information

- Blinking red light: automatic pairing and calibration. Do not touch the pedals.
- Blinking green light: ready to start training.
- Static red light: Error.

Transmitter Button Functions

- Press button for 1 second: switch transmitters on/off.
- Press and hold button for 5 seconds: access crank length selection mode.
- Press button for 1 second in crank length selection mode: change crank length.

9. IMPORTANT INFORMATION

Changing Batteries

It is recommended that you change both transmitter batteries at the same time. When the battery is low, a red light will blink once every two seconds when the automatic calibration has been completed.



The selected crank length is retained when changing the batteries.

Do not throw the old batteries away with normal waste; batteries should be disposed of properly according to local regulations.



Keep batteries away from children. If swallowed, contact a doctor immediately.

Changing Transmitter Sealing Rings

Additional sealing rings for the transmitters are included in the product package.

Remove the existing sealing rings carefully with tweezers. Using tweezers, place the new sealing rings carefully into the grooves.



When changing the sealing rings, use caution to avoid damaging them or the transmitters.

Maintenance



Before every ride, check your pedals and cleats to be sure they are free of dirt and that they are operating properly. Check your cleats daily for excessive wear, and replace as indicated. Worn cleats may release inadvertently and cause you to crash. Replace only with genuine LOOK Kéo cleats. Do not drill, paint or refinish. Keep pedals and cleats away from any heat source. Spindle: LOOK spindles are subjected to a rotation test of one million cycles at 100 revs / minute, with a load of 80 kg on the pedal and off centered rotation (which creates an impact at each rev). This test exceeds the toughest known standard EN 14781. High pressure cleaners are not recommended.

ENGLISH

Pedal Tension Adjustment

LOOK pedals are ALWAYS delivered pre-set to a minimum tension. Adjustment is carried out at the rear of the pedal, on the lever, using a 3 mm Allen key. By turning the key in the + direction (clockwise), you increase the amount of stress necessary for cleat release. Allow tension to remain minimal until you have become perfectly familiar with the system. Adjustment can not be carried out when the cleat is engaged in the pedal. You will hear a "click" when the maximum adjustment is reached. Once this click is heard, stop screwing as it may damage the pedal.

Engagement / Release

Engagement: Insert the cleat in the pedal in accordance with trajectory 1 and press down on the pedal as per trajectory 2 to lock the cleat.

Release: Rotate your heel towards the outside (picture 3) and it will disengage.



Do not release towards the inside, as this may cause the heel to touch the spokes and cause a crash.



Technical Specifications Polar P5 power transmitter

Operating temperature:	-10 °C to +50 °C
Storage temperature:	-20 °C to +60 °C
Battery type:	CR2354
Battery life:	Average 5 months (2h/day, 7days/week)
Water resistance:	IPX7 (Splash proof)

LOOK Kéo Power pedals

Operating temperature:	-10 °C to +50 °C
Storage temperature:	-20 °C to +60 °C
Distance crank/middle of the pedal	55 mm
Pedal float:	0, 4.5, or 9 degrees
Water resistance:	IPX7 (Splash proof)

Measurement ranges

Average power:	0 - 2000 W
L/R balance:	0 - 100 %
Cadence:	30 - 199 rpm
Maximum load:	1800 N

Limited International Polar Guarantee

- This guarantee does not affect the consumer's statutory rights under applicable national or state laws in force, or the consumer's rights against the dealer arising from their sales/purchase contract.
 - This limited Polar international guarantee is issued by Polar Electro Inc. for consumers who have purchased this product in the USA or Canada. This limited Polar international guarantee is issued by Polar Electro Oy for consumers who have purchased this product in other countries.
 - Polar Electro Oy/Polar Electro Inc. guarantees the original consumer/purchaser of this device that the product will be free from defects in material or workmanship for two (2) years from the date of purchase.
 - **The receipt of the original purchase is your proof of purchase!**
 - The guarantee does not cover the battery, normal wear and tear, damage due to misuse, abuse, accidents or non-compliance with the precautions; improper maintenance, commercial use, cracked, broken or scratched cases/displays, armband, elastic strap and Polar apparel.
- The guarantee does not cover any damage/s, losses, costs or expenses, direct, indirect or incidental, consequential or special, arising out of, or related to the product.
 - Items purchased second hand are not covered by the two (2) year warranty, unless otherwise stipulated by local law.
 - During the guarantee period, the product will be either repaired or replaced at any of the authorized Polar Service Centers regardless of the country of purchase.

Guarantee with respect to any product will be limited to countries where the product has been initially marketed.



This product is compliant with Directive 93/42/EEC. The relevant Declaration of Conformity is available at www.support.polar.fi/declaration_of_conformity.

Regulatory information is available at www.polar.fi/support.



This crossed out wheeled bin marking shows that Polar products are electronic devices and are in the scope of Directive 2002/96/EC of the European Parliament and of the Council on waste electrical and electronic equipment (WEEE) and batteries and accumulators used in products are in the scope of Directive 2006/66/EC of the European Parliament and of the Council of 6 September 2006 on batteries and accumulators and waste batteries and accumulators. These products and batteries/accumulators inside Polar products should thus be disposed of separately in EU countries. Polar encourages you to minimize possible effects of waste on the environment and human health also outside the European Union by following local waste disposal regulations and, where possible, utilize separate collection of electronic devices for products, and battery and accumulator collection for batteries and accumulators.

Copyright © 2011 Polar Electro Oy, FIN-90440
KEMPELE, Finland.

Polar Electro Oy is a ISO 9001:2008 certified company.

All rights reserved. No part of this manual may be used or reproduced in any form or by any means without prior written permission of Polar Electro Oy. The names and logos marked with a ™ symbol in this user manual or in the package of this product are trademarks of Polar Electro Oy. The names and logos marked with a ® symbol in this user manual or in the package of this product are registered trademarks of Polar Electro Oy.

LOOK Limited Warranty

Please keep your proof of purchase and register your warranty on line at www.lookcycle.com

If you register on line, you need not return the coupon “carte de garantie” but you must keep your proof of purchase. LOOK pedals provide the latest and best technology in the field of automatic pedals. They can not, however, guarantee safety in the event of accident. LOOK, through its authorized distributor in the country in which this product was first sold at retail, warrants to the first retail purchaser or user that this product shall be free from defects in materials and workmanship. This Limited Warranty, as well as any implied warranty, shall expire 2 years from date of the initial retail purchase. This limited warranty does not apply to ordinary wear and tear (including worn out cleats), parts which have been refinished or subjected to improper repairs or modifications, or to damage caused by accident, abuse,

lack of reasonable care or improper use. Improper use which will void this warranty includes spinning, jumping, acrobatics, extreme cycling and similar activities. The sole remedy under the LOOK limited warranty or any implied warranty shall be limited to the repair or replacement, at LOOK's sole option, of the subject product or parts thereof. In no event shall LOOK or its agents or distributors be liable for incidental or consequential damages or for any cost of transporting or shipping the product, whether the claim is based upon contract, warranty, negligence or product liability, including, without limitation, loss or damage to property other than the warranted product itself, loss of use of any property, or other economic losses. Neither LOOK nor any agent or distributor shall be liable for contribution or indemnification, whatever the cause. Warranty rights and remedies may not be assigned or transferred. LOOK's obligations under any warranty shall be limited, to the greatest extent allowed by law, as provided in this LOOK Limited Warranty. Some states do not allow limitations on how long an implied warranty lasts and/or the exclusion or limitation of incidental or consequential damages, so the above limitation and exclusion may not apply to you. This Limited Warranty gives you specific legal rights, and you may also have other rights which vary from state to state.

Disclaimer

- The material in this manual is for informational purposes only. The products it describes are subject to change without prior notice, due to the manufacturer's continuous development program.
- Polar Electro Inc. / Polar Electro Oy makes no representations or warranties with respect to this manual or with respect to the products described herein.
- Polar Electro Inc. / Polar Electro Oy shall not be liable for any damages, losses, costs or expenses, direct, indirect or incidental, consequential or special, arising out of, or related to the use of this material or the products described herein.



POLAR[®]
LISTEN TO YOUR BODY